

## APPLICATION TECH NOTE

**PRODUCTS SUPPORTED:**  
CONVERGE® Huddle

CLEARONE DOCUMENT NTS-0114-001 (v1.0)  
January, 15, 2021

### AEC Options using CONVERGE Huddle:

#### Acoustic Echo Cancellation: OVERVIEW

CONVERGE Huddle's Acoustic Echo Cancellation can be applied in the following methods

1. Use the built in AEC of the CONVERGE Huddle with reference to one of the built in amplifier outputs.

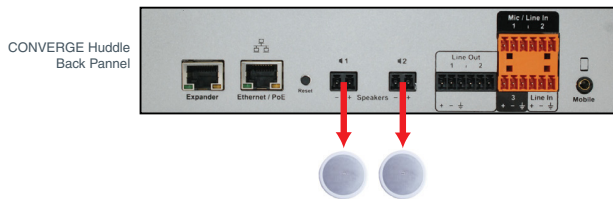

The AEC will reference the speaker output 1 or speaker output 2. Amplification is built into the CONVERGE Huddle.

Speakers

2. Use the built in AEC of the CONVERGE Huddle with reference to one of the line outputs. You will use an external amplifier to drive speakers in this case.

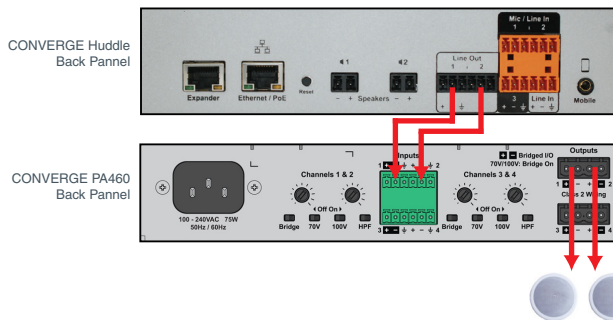

The AEC will reference the Line Out 1 or Line Out 2.

External amplification required. (CONVERGE PA460 shown)

Speakers

3. Use custom firmware from ClearOne to avail audio output from HDMI port to connect through TV speakers. In this case, the AEC from CONVERGE Huddle is disabled and users will depend on echo cancellation built into the software conferencing tools such as Zoom, MS Teams, etc.



The AEC will be handled by 3rd party software.

Speakers (built into display)

### SALES AND INQUIRIES

#### Headquarters

5225 Wiley Post Way  
Suite 500  
Salt Lake City, UT 84116

#### US & Canada

Tel: 801.975.7200  
Toll Free: 800.945.7730  
Fax: 801.303.5711

#### International

Tel: +1.801.975.7200  
global@clearone.com

#### Sales

Tel: 801.975.7200  
sales@clearone.com

#### Tech Support

Tel: 801.974.3760  
tech.support@clearone.com