

ClearOne.

UNITE[®] 150 CAMERA QUICK START GUIDE

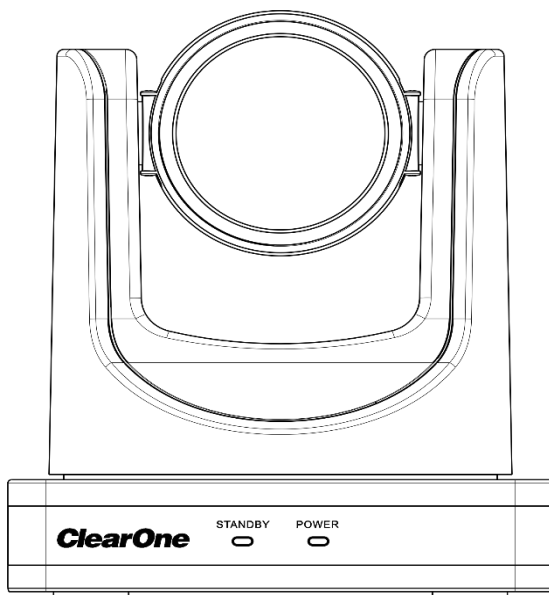

COPYRIGHT NOTICE

ClearOne	
5225 Wiley Post Way	
Suite 500	
Salt Lake City, UT 84116	
Telephone	1.801.975.7200
Tech Sales	1.801.974.3760
Fax	1.801.303.5711
E-mail	collaborate.support@clearone.com
On the Web	www.clearone.com

UNITE® 150 QUICK START GUIDE

CLEARONE DOCUMENT

QSG-0087-001 REV 1.1 – March 2020

© 2020 ClearOne Inc. - All rights reserved. No part of this document may be reproduced in any form or by any means without written permission from ClearOne. Printed in the United States of America. ClearOne reserves specific privileges. Information in this document is subject to change without notice.

NOTICE: This Class A device complies with Part 15 of the FCC rules and Canadian ICES-003. Operation is subject to the following two conditions: (1) this device may not cause harmful interference, and (2) this device must accept any interference received, including interference that may cause undesired operation.

CONTENTS

COPYRIGHT NOTICE2

CONTENTS	2
PREFACE.....	4
PRECAUTIONS.....	4
SUPPLIED ACCESSORIES.....	6
QUICK START	7
FEATURES.....	8
PRODUCT SPECIFICATION	9
MAIN UNIT.....	10
SIZE	11
IR REMOTE CONTROL	12
SERIAL COMMUNICATION CONTROL.....	15
MENU SETTING.....	26
USB 3.0	34
MAINTENANCE AND TROUBLESHOOTING.....	34

PREFACE

This Quick Start Guide introduces the function, installation, and operation of the UNITE® 150 camera. Prior to installation and usage, please thoroughly read this document.

PRECAUTIONS

This product can be used only under the specified conditions in order to avoid any damage to the camera:

- Do not subject the camera to rain or moisture.
- Do not remove the cover; otherwise, you may get an electric shock. In case of abnormal operation, contact ClearOne Technical Support.
- Never operate outside the specified temperature, humidity, and power supply recommendations.
- Use a soft dry cloth to clean the camera. If the camera is very dirty, clean it with diluted neutral detergent; do not use any type of solvents, which may damage the surface.

Caution to transport

Avoid stress, vibration, and moisture in transport, storage, and installation.

During installation, take the following precautions:

- Do not grasp the camera by the head when carrying the camera.
- Do not turn camera head manually. Doing so may result in mechanical damage.
- Do not apply corrosive liquid, gas or solid, to avoid damaging the plastic cover.
- Make sure there are no obstacles within the camera's rotation range.
- Never power on before installation has been completed.

Do not dismantle the camera

ClearOne is not responsible for any unauthorized modification or dismantling.

SUPPLIED ACCESSORIES

When you unpack, check that all the supplied accessories are included:

- Camera
- AC power adapter
- Power cord
- RS232 cable
- Remote controller
- User manual
- USB 3.0 cable

QUICK START

Step 1. Refer to the diagram below to make sure the connections are correct.

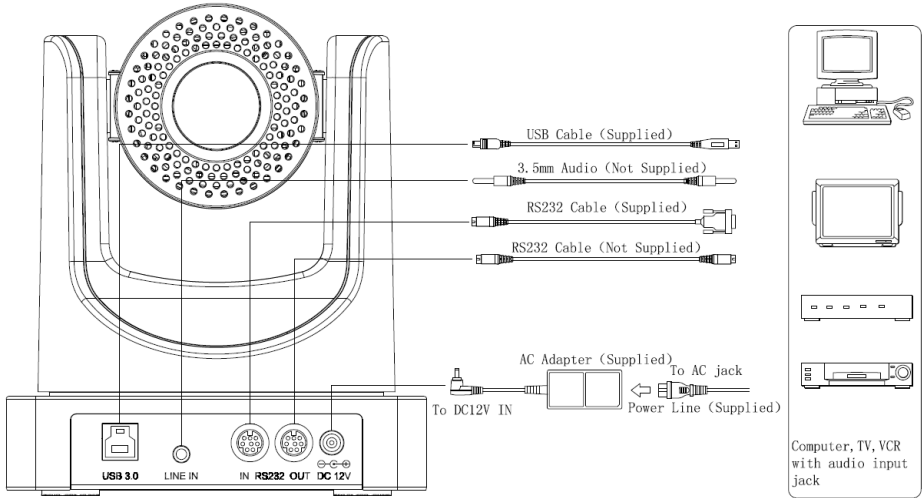

Step2. Connect to the power. The LED light on the front panel indicates the camera is powered on.

Step3. The process of initialization is complete after the camera pan-tilt rotates to the maximum position of top right and returns to the center.

Note: If the position preset 0 has been stored, the position preset 0 will be called up after initialization.

FEATURES

- **Full Function USB Interface**

USB 3.0 ultra-high speed interface; can transfer uncompressed original video, and downward compatible with USB 2.0; support UVC, UAC protocol.

- **1080P Full HD**

Apply Panasonic's 1/2.7 inch, 2.07 million effective pixels high quality HD CMOS sensor; can reach maximum 1920 x 1080 high resolution and achieve quality image.

- **72.5° Wide-angle Lens**

A 72.5° wide-angle high quality lens supports 12x optical zoom.

- **AAC Audio Encoding**

Supports audio line input. Supports AAC audio encoding for better sound quality and lower bandwidth.

- **Low-light**

High SNR of CMOS sensor combined with 2D and 3D noise reduction algorithm effectively reduces noise. Even under low illumination conditions, the image can remain clear and sharp.

- **Remote Control**

All the parameters of the camera can be remotely controlled using the RS232 and USB interfaces.

PRODUCT SPECIFICATION

Details	
Model	UNITE® 150
Name	UNITE® USB 3.0 HD Video Conference Camera
Camera	
Video System	HD: 1080p/30, 1080p/25, 720p/30, 720p/25
Sensor	1/2.7", CMOS, Effective Pixel: 2.07M
Scanning Mode	Progressive
Lens	12x, f3.5mm ~ 42.3mm, F1.8 ~ F2.8
Minimal Illumination	0.5 Lux @ (F1.8, AGC ON)
Shutter	1/30s ~ 1/10000s
White Balance	Auto, Indoor, Outdoor, One Push, Manual
Backlight Compensation	Support
Digital Noise Reduction	2D & 3D Digital Noise Reduction
Video S/N	≥55dB
Horizontal Angle of View	72.5° ~ 6.9°
Vertical Angle of View	44.8° ~ 3.9°
Horizontal Rotation Range	±170°
Vertical Rotation Range	-30° ~ +90°
Pan Speed Range	1.7° ~ 100°/s
Tilt Speed Range	1.7° ~ 69.9°/s
H & V Flip	Support
Image Freeze	Support
Number of Preset	255
Preset Accuracy	0.1°
USB Features	

Operate System	Windows 7, Windows 8, Windows 8.1, Windows 10, Mac OSX, Linux
Color System/Compression	YUV 4:2:2
Video Format	USB 3.0: 1080p/30, 1080p/25, 720p/30, 720p/25
Audio on USB	Support
USB Video Communication Protocol	UVC 1.0 ~ UVC 1.5
UVC PTZ	Support
Input / Output Interface	
USB Interface	1xUSB 3.0: Type B female jack
Audio Interface	1-ch: 3.5mm Audio Interface, Line In
Communication Interface	1xRS232 In: 8pin Min DIN, Max Distance: 30m, Protocol: VISCA/Pelco-D/Pelco-P
	1xRS232 Out: 8pin Min DIN, Max Distance: 30m, Protocol: VISCA network use only
Power Jack	JEITA type (DC IN 12V)
Generic Specification	
Input Voltage	DC 12V
Current Consumption	1.0A (Max)
Operating Temperature	-10°C ~ 40°C (14°F ~ 104°F)
Storage Temperature	-40°C ~ 60°C (-40°F ~ 140°F)
Power Consumption	12W (Max)
MTBF	>30000h
Size	144mm x144mm x168mm
Net Weight	0.91kg

MAIN UNIT

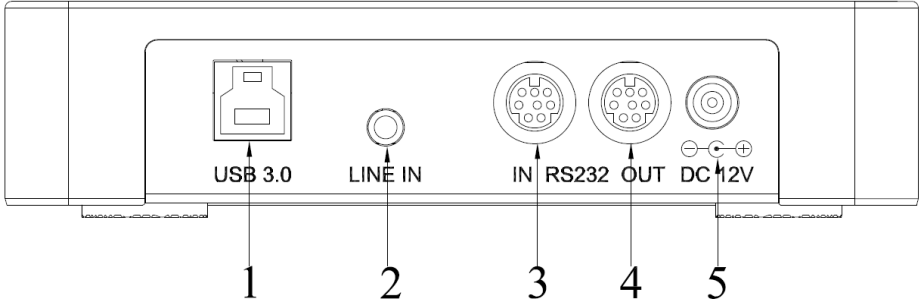

1. USB 3.0

2. Line In Interface

3. RS232 In Interface

4. RS232 Out Interface

5. DC Power 12V Jack

SIZE

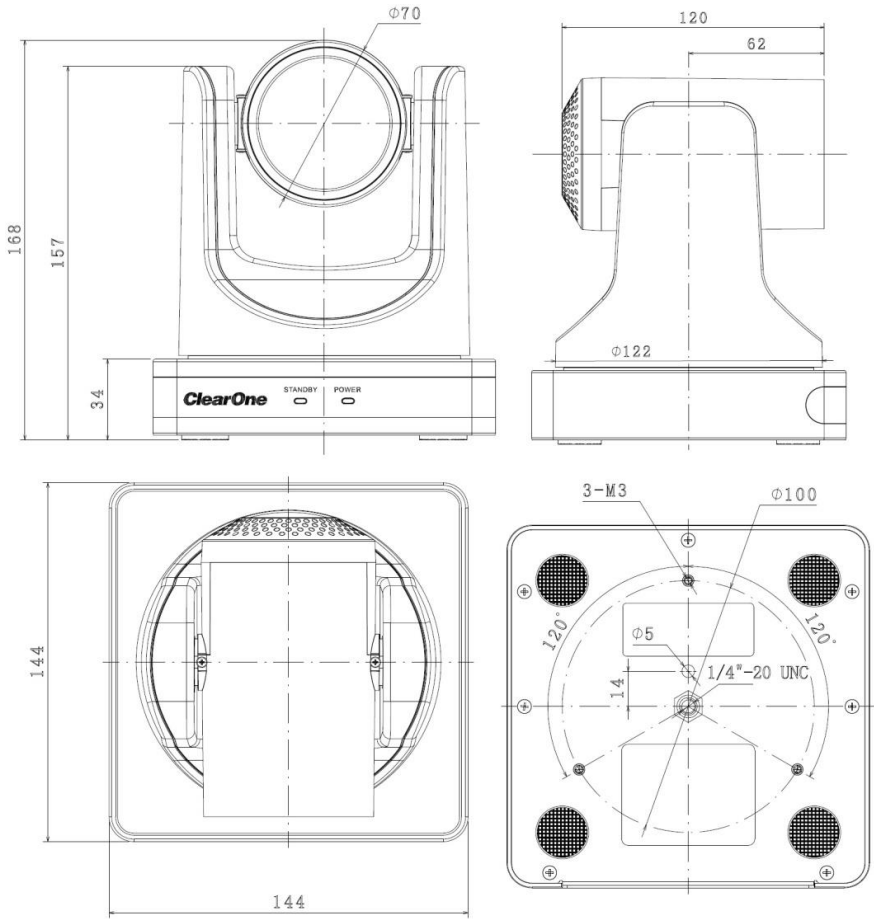

Unit: mm

IR REMOTE CONTROL

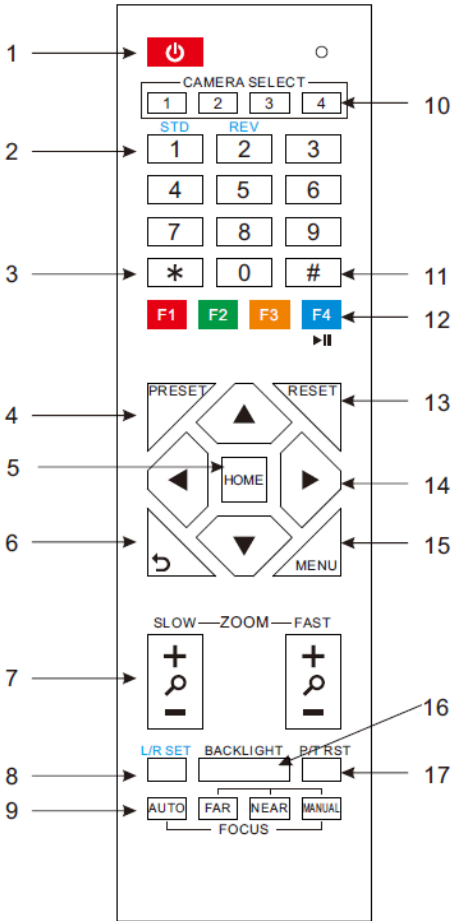

1. Standby Button

Press this button to enter standby mode.

Press it again to enter normal mode. **Note:** Power consumption in standby mode is approximately half of the normal mode

2. Position Buttons

To set preset or call preset

3. * Button

4. Set/Preset Buttons

Set a corresponding numeric key preset position

[PRESET] + Numeric button (0-9)

Note: Preset 0-9 via remote control and the rest from keyboard and the serial port.

5. Pan-Tilt Control Buttons

Press the arrow buttons to perform panning and tilting. Press the [HOME] button to face the camera back to front.

6. Back Buttons

Press OSD menu to return to previous menu.

7. Zoom Buttons

Slow Zoom: Zoom In [+] or Zoom Out [-] slowly

Fast Zoom: Zoom In [+] or Zoom Out [-] fast

8. L/R Set Button

Press at the same time as the numeric button 1 [STD] and button 2 [REV] to set the

direction of the Pan-Tilt

L/R Set +1[STD]: set the Pan-Tilt turn the same direction as the L/R Set

L/R Set +2[REV]: set the Pan-Tilt turn the opposite direction as the L/R Set

9. Focus Buttons

Press [AUTO] to adjust the focus on the center of the object automatically.

Press [MANUAL] to adjust the focus manually.

Press [FAR] to focus on a far object.

Press [NEAR] to focus on a near object.

10. Camera Select Buttons

Press the button corresponding to the camera you want to control with the remote controller.

11. # Button

Used with other buttons

12. Set Camera IR Address Buttons

[*]+[#]+[F1]: Address1

[*]+[#]+[F2]: Address2

[*]+[#]+[F3]: Address3

[*]+[#]+[F4]: Address4

13. Reset Buttons

Clear a specific preset: [Reset] + Numeric button (0-9)

Clear all presets: [*]+[#]+[Reset]: Erase all presets

14. Pan/Tilt Control Buttons

Press arrow buttons to perform panning and tilting. Press [HOME] button to face the camera back to front.

15. MENU

Press MENU to enter or exit the OSD menu.

16. BLC (Backlight Compensation) Button

If there is light behind the subject, the subject will appear dark.

Press this button to enable the backlight compensation. Press it again to disable the backlight compensation.

Press the backlight ON / OFF button. To cancel this function, press the backlight ON / OFF button.

Note: The BLC feature is effective only in auto exposure mode.

17. Pan/Tilt Reset

Reset Pan/Tilt self-test.

18. Shortcut Set

[*]+[#]+[1]: Display OSD menu in English

[*]+[#]+[3]: Display OSD menu in Chinese

[*]+[#]+[5]: Save OSD

[*]+[#]+[6]: Quickly recover the default settings

[*]+[#]+[8]: Show the camera version

[*]+[#]+[9]: Quickly set mount mode (flip/normal)

SERIAL COMMUNICATION CONTROL

In default working mode, the camera can be controlled via RS232 or RS485 (half-duplex mode). The parameters are as follows:

Baud rate: 2400/4800/9600 bit/s.

Start bit: 1 bit.

Data bit: 8 bits.

Stop bit: 1bit.

Parity bit: none.

The process of initialization is complete when the camera pan-tilt rotates to the maximum position of top right and then returns to the center.

Note: If the position preset 0 has been stored, the position preset 0 is called up after initialization, and users will be able to control the camera with commands in the following command list.

Control Interface Definition

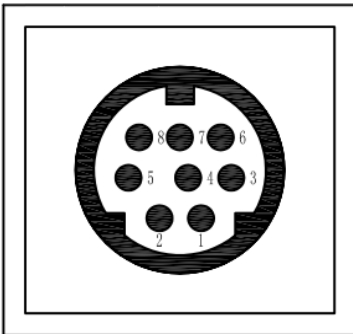

Pin No.	Function
1	DTR
2	DSR
3	TXD
4	GND
5	RXD
6	RS485-
7	IR OUT
8	RS485+

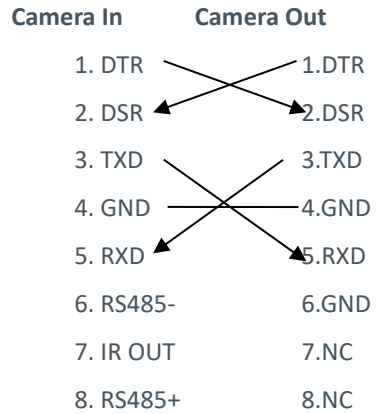
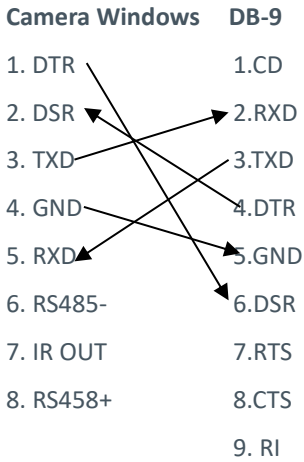

Command List

The camera uses the VISCA/Pelco-D/Pelco-P serial standard.

Part 1 Camera-Issued Messages

ACK/ Completion Message			
Command	Function	Command Packet	Comments
ACK/Completion Messages	ACK	z0 4y FF (y: Socket No.)	Returned when the command is accepted.
	Completion	z0 5y FF (y: Socket No.)	Returned when the command has been executed.

*z = Camera Address + 8

Error Messages			
Command	Function	Command Packet	Comments
Error Messages	Syntax Error	z0 60 02 FF	Returned when the command format is different or when a command with illegal command parameters is accepted.
	Command Buffer Full	z0 60 03 FF	Indicates that two sockets are already being used (executing two commands) and the command could not be accepted when received.
	Command Canceled	z0 6y 04 FF (y: Socket No.)	Returned when a command which is being executed in a socket specified by the cancel command is canceled. The completion message for the command is not returned.
	No Socket	z0 6y 05 FF (y: Socket No.)	Returned when no command is executed in a socket specified by the cancel command, or when an invalid socket number is specified.
	Command Not Executable	z0 6y 41 FF (y: Execution command Socket No. Inquiry command: 0)	Returned when a command can't be executed due to current conditions. For example, when commands controlling the focus manually are received during auto focus.

Part 2 Camera Control Command

Command	Function	Command Packet	Comments
AddressSet	Broadcast	88 30 01 FF	Address setting
CAM_Zoom	Stop	8x 01 04 07 00 FF	
	Tele(Standard)	8x 01 04 07 02 FF	
	Wide(Standard)	8x 01 04 07 03 FF	
	Tele(Variable)	8x 01 04 07 2p FF	p = 0(low) - 7(high)
	Wide(Variable)	8x 01 04 07 3p FF	
	Direct	8x 01 04 47 0p 0q 0r 0s FF	pqrs: Zoom Position
CAM_Focus	Stop	8x 01 04 08 00 FF	
	Far(Standard)	8x 01 04 08 02 FF	
	Near(Standard)	8x 01 04 08 03 FF	
	Far(Variable)	8x 01 04 08 2p FF	p = 0(low) - 7(high)
	Near(Variable)	8x 01 04 08 3p FF	
	Direct	8x 01 04 48 0p 0q 0r 0s FF	pqrs: Focus Position
	Auto Focus	8x 01 04 38 02 FF	AF On/Off
	Manual Focus	8x 01 04 38 03 FF	
	Auto/Manual	8x 01 04 38 10 FF	
CAM_WB	Auto	8x 01 04 35 00 FF	Normal Auto
	Indoor mode	8x 01 04 35 01 FF	Indoor mode
	Outdoor mode	8x 01 04 35 02 FF	Outdoor mode
	OnePush mode	8x 01 04 35 03 FF	One Push WB mode
	Manual	8x 01 04 35 05 FF	Manual Control mode
	OnePush trigger	8x 01 04 10 05 FF	One Push WB Trigger
CAM_RGain	Reset	8x 01 04 03 00 FF	Manual Control of R Gain
	Up	8x 01 04 03 02 FF	
	Down	8x 01 04 03 03 FF	

Command	Function	Command Packet	Comments
	Direct	8x 01 04 43 00 00 0p 0q FF	pq: R Gain
CAM_Bgain	Reset	8x 01 04 04 00 FF	Manual Control of B Gain
	Up	8x 01 04 04 02 FF	
	Down	8x 01 04 04 03 FF	
	Direct	8x 01 04 44 00 00 0p 0q FF	pq: B Gain
CAM_AE	Full Auto	8x 01 04 39 00 FF	Automatic Exposure mode
	Manual	8x 01 04 39 03 FF	Manual Control mode
	Shutter priority	8x 01 04 39 0A FF	Shutter Priority Automatic Exposure mode
	Iris priority	8x 01 04 39 0B FF	Iris Priority Automatic Exposure mode
	Bright	8x 01 04 39 0D FF	Bright mode (Manual control)
CAM_Iris	Reset	8x 01 04 0B 00 FF	Iris Setting
	Up	8x 01 04 0B 02 FF	
	Down	8x 01 04 0B 03 FF	
	Direct	8x 01 04 4B 00 00 0p 0q FF	pq: Iris Position
CAM_Gain	Reset	8x 01 04 0C 00 FF	Gain Setting
	Up	8x 01 04 0C 02 FF	
	Down	8x 01 04 0C 03 FF	
	Direct	8x 01 04 0C 00 00 0p 0q FF	pq: Gain Position
	Gain Limit	8x 01 04 2C 0p FF	p: Gain Position
CAM_Bright	Reset	8x 01 04 0D 00 FF	Bright Setting
	Up	8x 01 04 0D 02 FF	
	Down	8x 01 04 0D 03 FF	

Command	Function	Command Packet	Comments
	Direct	8x 01 04 0D 00 00 0p 0q FF	pq: Bright Position
CAM_ExpComp	On	8x 01 04 3E 02 FF	Exposure
	Off	8x 01 04 3E 03 FF	Compensation On/Off
	Reset	8x 01 04 0E 00 FF	Exposure
	Up	8x 01 04 0E 02 FF	Compensation Amount
	Down	8x 01 04 0E 03 FF	Setting
	Direct	8x 01 04 4E 00 00 0p 0q FF	pq: ExpComp Position
CAM_BackLight	On	8x 01 04 33 02 FF	Back Light
	Off	8x 01 04 33 03 FF	Compensation On/Off
CAM_NR(2D)Mode	Auto	8x 01 04 50 02 FF	ND2D Auto/Manual
	Manual	8x 01 04 50 03 FF	
CAM_NR(2D)Level	-	8x 01 04 53 0p FF	p: NR Setting (0: Off, level 1 to 5)
CAM_NR(3D)Level	-	8x 01 04 54 0p FF	p: NR Setting (0: Off, level 1 to 8)
CAM_Flicker	-	8x 01 04 23 0p FF	p: Flicker Settings (0: Off, 1: 50Hz, 2: 60Hz)
CAM_DHotPixel	-	8x 01 04 56 0p FF	p: Dynamic Hot Pixel Setting (0: Off, level 1 to 6)
CAM_ApertureMode (sharpness)	Auto	8x 01 04 05 02 FF	Sharpness Auto
	Manual	8x 01 04 05 02 FF	Sharpness Manual
CAM_Aperture(shar pness)	Reset	8x 01 04 02 00 FF	Aperture Control
	Up	8x 01 04 02 02 FF	
	Down	8x 01 04 02 03 FF	
	Direct	8x 01 04 42 00 00 0p 0q FF	pq: Aperture Gain

Command	Function	Command Packet	Comments
CAM_PictureEffect	Off	8x 01 04 63 00 FF	Picture Effect Setting
	B&W	8x 01 04 63 04 FF	
CAM_Memory	Reset	8x 01 04 3F 00 pp FF	pp: Memory Number(=0 to 127)
	Set	8x 01 04 3F 01 pp FF	
	Recall	8x 01 04 3F 02 pp FF	
CAM_LR_Reverse	On	8x 01 04 61 02 FF	Image Flip Horizontal
	Off	8x 01 04 61 03 FF	On/Off
CAM_PictureFlip	On	8x 01 04 66 02 FF	Image Flip Vertical
	Off	8x 01 04 66 03 FF	On/Off
CAM_ColorGain	Diret	8x 01 04 49 00 00 00 0p FF	p: Color Gain setting 0h (60%) to Eh (200%)
SYS_Menu	Off	8x 01 06 06 03 FF	Turns on/off the menu screen
	On	8x 01 06 06 02 FF	
Pan_tiltDrive	Up	8x 01 06 01 VV WW 03 01 FF	VV: Pan speed 0x01 (low speed) to 0x18 (high speed) WW: Tilt speed 0x01 (low speed) to 0x14 (high speed) YYYY: Pan Position ZZZZ: Tilt Position
	Down	8x 01 06 01 VV WW 03 02 FF	
	Left	8x 01 06 01 VV WW 01 03 FF	
	Right	8x 01 06 01 VV WW 02 03 FF	
	Upleft	8x 01 06 01 VV WW 01 01 FF	
	Upright	8x 01 06 01 VV WW 02 01 FF	
	DownLeft	8x 01 06 01 VV WW 01 02 FF	
	DownRight	8x 01 06 01 VV WW 02 02 FF	
	Stop	8x 01 06 01 VV WW 03 03 FF	
	AbsolutePosition	8x 01 06 02 VV WW 0Y 0Y 0Y 0Y 0Z 0Z 0Z 0Z FF	
	RelativePosition	8x 01 06 03 VV WW 0Y 0Y 0Y 0Y 0Z 0Z 0Z 0Z FF	
	Home	8x 01 06 04 FF	

Command	Function	Command Packet	Comments
	Reset	8x 01 06 05 FF	
Pan_tiltLimitSet	LimitSet	8x 01 06 07 00 0W 0Y 0Y 0Y 0Y 0Z 0Z 0Z 0Z FF	W: 1 UpRight 0: DownLeft
	LimitClear	8x 01 06 07 01 0W 07 0F 0F 0F 07 0F 0F 0F FF	YYYY: Pan Limit Position ZZZZ: Tilt Position
CAM_AFSensitivity	High	8x 01 04 58 01 FF	AF Sensitivity High/Normal/Low
	Normal	8x 01 04 58 02 FF	
	Low	8x 01 04 58 03 FF	
CAM_SettingReset	Reset	8x 01 04 A0 10 FF	Reset Factory Setting
CAM_Brightness	Direct	8x 01 04 A1 00 00 0p 0q FF	pq: Brightness Position
CAM_Contrast	Direct	8x 01 04 A2 00 00 0p 0q FF	pq: Contrast Position
CAM_Flip	Off	8x 01 04 A4 00 FF	Single Command For Video Flip
	Flip-H	8x 01 04 A4 01 FF	
	Flip-V	8x 01 04 A4 02 FF	
	Flip-HV	8x 01 04 A4 03 FF	
CAM_SettingSave	Save	8x 01 04 A5 10 FF	Save Current Setting
CAM_Iridix	Direct	8x 01 04 A7 00 00 0p 0q FF	pq: Iridix Position
CAM_AWBSensitivity	High	8x 01 04 A9 00 FF	High
	Normal	8x 01 04 A9 01 FF	Normal
	Low	8x 01 04 A9 02 FF	Low
CAM_AFZone	Top	8x 01 04 AA 00 FF	AF Zone weight select
	Center	8x 01 04 AA 01 FF	
	Bottom	8x 01 04 AA 02 FF	
CAM_ColorHue	Direct	8x 01 04 4F 00 00 00 0p FF	p: Color Hue setting 0h (- 14 degrees) to Eh (+14 degrees)

Part 3 Demand Command

Command	Command Packed	Return Values	Comments
CAM_ZoomPosInq	8x 09 04 47 FF	y0 50 0p 0q 0r 0s FF	pqrs: Zoom Position
CAM_FocusAFModelInq	8x 09 04 38 FF	y0 50 02 FF	Auto Focus
		y0 50 03 FF	Manual Focus
CAM_FocusPosInq	8x 09 04 48 FF	y0 50 0p 0q 0r 0s FF	pqrs: Focus Position
CAM_WBModelInq	8x 09 04 35 FF	y0 50 00 FF	Auto
		y0 50 01 FF	Indoor mode
		y0 50 02 FF	Outdoor mode
		y0 50 03 FF	OnePush mode
		y0 50 05 FF	Manual
CAM_RGainInq	8x 09 04 43 FF	y0 50 00 00 0p 0q FF	pq: R Gain
CAM_BGainInq	8x 09 04 44 FF	y0 50 00 00 0p 0q FF	pq: B Gain
CAM_AEModelInq	8x 09 04 39 FF	y0 50 00 FF	Full Auto
		y0 50 03 FF	Manual
		y0 50 0A FF	Shutter priority
		y0 50 0B FF	Iris priority
		y0 50 0D FF	Bright
CAM_ShutterPosInq	8x 09 04 4A FF	y0 50 00 00 0p 0q FF	pq: Shutter Position
CAM_IrisPosInq	8x 09 04 4B FF	y0 50 00 00 0p 0q FF	pq: Iris Position
CAM_BrightPosInq	8x 09 04 4D FF	y0 50 00 00 0p 0q FF	pq: Bright Position
CAM_ExpCompModelInq	8x 09 04 3E FF	y0 50 02 FF	On
		y0 50 03 FF	Off
CAM_ExpCompPosInq	8x 09 04 4E FF	y0 50 00 00 0p 0q FF	pq: ExpComp Position
CAM_BacklightModelInq	8x 09 04 33 FF	y0 50 02 FF	On
		y0 50 03 FF	Off

Command	Command Packed	Return Values	Comments
CAM_Noise2DModelInq	8x 09 04 50 FF	y0 50 02 FF	Auto Noise 2D
		y0 50 03 FF	Manual Noise 3D
CAM_Noise2DLevel	8x 09 04 53 FF	y0 50 0p FF	Noise Reduction (2D) p: 0 to 5
CAM_Noise3DLevel	8x 09 04 54 FF	y0 50 0p FF	Noise Reduction (3D) p: 0 to 8
CAM_FlickerModelInq	8x 09 04 55 FF	y0 50 0p FF	p: Flicker Settings(0: OFF, 1: 50Hz, 2: 60Hz)
CAM_ApertureModelInq (Sharpness)	8x 09 04 05 FF	y0 50 02 FF	Auto Sharpness
		y0 50 03 FF	Manual Sharpness
CAM_ApertureInq(Sharpness)	8x 09 04 42 FF	y0 50 00 00 0p 0q FF	ppq: Aperture Gain
CAM_PictureEffectModelInq	8x 09 04 63 FF	y0 50 02 FF	Off
		y0 50 04 FF	B&W
CAM_MemoryInq	8x 09 04 3F FF	y0 50 0p FF	p: Memory number last operated.
SYS_MenuModelInq	8x 09 06 06 FF	y0 50 02 FF	On
		y0 50 03 FF	Off
CAM_LR_ReverseInq	8x 09 04 61 FF	y0 50 02 FF	On
		y0 50 03 FF	Off
CAM_PictureFlipInq	8x 09 04 66 FF	y0 50 02 FF	On
		y0 50 03 FF	Off
CAM_ColorGainInq	8x 09 04 49 FF	y0 50 00 00 00 0p FF	p: Color Gain setting 0h (60%) to Eh (200%)
VideoSystemInq	8x 09 06 23 FF	y0 50 00 FF	1920x1080i60
		y0 50 01 FF	1920x1080p30
		y0 50 02 FF	1280x720p60

Command	Command Packed	Return Values	Comments
		y0 50 04 FF	NTSC
		y0 50 05 FF	NTSC
		y0 50 06 FF	NTSC
		y0 50 07 FF	1920x1080p60
		y0 50 08 FF	1920x1080i50
		y0 50 09 FF	1920x1080p25
		y0 50 0A FF	1280x720p50
		y0 50 0C FF	PAL
		y0 50 0D FF	PAL
		y0 50 0E FF	PAL
Pan-tiltMaxSpeedInq	8x 09 06 11 FF	y0 50 ww zz FF	ww: Pan Max Speed zz: Tilt Max Speed
Pan-tiltPosInq	8x 09 06 12 FF	y0 50 0w 0w 0w 0w 0z 0z 0z 0z FF	www: Pan Position zzz: Tilt Position
CAM_GainLimitInq	8x 09 04 2C FF	y0 50 0q FF	p: Gain Limit
CAM_DHotPixelInq	8x 09 04 56 FF	y0 50 0q FF	p: Dynamic Hot Pixel Setting (0: Off, level 1 to 6)
CAM_AFSensitivityInq	8x 09 04 58 FF	y0 50 01 FF	High
		y0 50 02 FF	Normal
		y0 50 03 FF	Low
CAM_BrightnessInq	8x 09 04 A1 FF	y0 50 00 00 0p 0q FF	pq: Brightness Position
CAM_ContrastInq	8x 09 04 A2 FF	y0 50 00 00 0p 0q FF	pq: Contrast Position
CAM_FlipInq	8x 09 04 A4 FF	y0 50 00 FF	Off
		y0 50 01 FF	Flip-H
		y0 50 02 FF	Flip-V
		y0 50 03 FF	Flip-HV

Command	Command Packed	Return Values	Comments
CAM_IridixInq	8x 09 04 A7 FF	y0 50 00 00 0p 0q FF	pq: Iridix Position
CAM_AFZone	8x 09 04 AA FF	y0 50 00 FF	Top
		y0 50 01 FF	Center
		y0 50 02 FF	Bottom
CAM_ColorHueInq	8x 09 04 4F FF	y0 50 00 00 00 0p FF	p: Color Hue setting 0h (– 14 dgrades) to Eh (+14 degrees)
CAM_AWBSensitivityInq	8x 09 04 A9 FF	y0 50 00 FF	High
		y0 50 01 FF	Normal
		y0 50 02 FF	Low

MENU SETTING

1. MENU

Press the [MENU] button to display the main menu. Use the arrow buttons to select the item to be set. Press the [HOME] button to enter a sub-menu.

MENU
▶ Exposure
Color
Image
P/T/Z
Noise Reduction
Setup
Communication Setup
Restore Default
[Home] Enter
[Menu] Exit

2. EXPOSURE

Select Exposure from the main menu and press the [HOME] button. The EXPOSURE menu appears, as shown in the following figure:

EXPOSURE	
▶ Mode	Auto
ExpCompMode	Off
Backlight	Off
Gain Limit	2
Anti-Flicker	60Hz
Meter	Average
DRC	2
▲▼ Select Item	
◀▶ Change Value	
[Menu] Back	

➤ Mode: Exposure mode

Options:

- Auto
- Manual
- SAE
- AAE
- Bright

➤ ExpCompMode: Exposure compensation mode

Note: This feature is only effective when exposure mode is set to

Auto.

Options:

- On
- Off

➤ ExpComp: Exposure compensation value

Note: This feature is only effective when ExpCompMode is on.

Options: -7 ~ 7

➤ Gain Limit: Maximum gain limit

Note: This feature is only effective when exposure mode is set to Auto/AAE/Bright.

Options: 0 ~ 15

➤ Backlight: Set the backlight compensation

Note: This feature is only effective when exposure mode is set to Auto.

Options:

- On
- Off

➤ DRC: DRC strength

Options: 0 ~ 8

➤ Bright: Intensity control

Note: This feature is only effective when exposure mode is set to Bright.

Options: 00~17

➤ Anti-Flicker Flicker: Anti-flicker

Note: This feature is only effective

when exposure mode is set to Auto/Bright.

Options:

- Off
- 50Hz
- 60Hz

➤ Meter

Options:

- Average
- Center
- Bottom
- Top

➤ Iris: Aperture Value

Note: This feature is only effective when exposure mode is set to Manual/AE.

Options:

- F1.8
- F2.0
- F2.4
- F2.8
- F3.4
- F4.0
- F4.8
- F5.6
- F6.8
- F8.0
- F9.6
- F11.0
- Close

➤ Shutter: Shutter value

Note: This feature is only effective when exposure mode is set to Manual/SAE.

Options:

- 1/30
- 1/60
- 1/90
- 1/100
- 1/125
- 1/180
- 1/250
- 1/350
- 1/500
- 1/725
- 1/1000
- 1/1500
- 1/2000
- 1/3000
- 1/4000
- 1/6000
- 1/10000

3. COLOR

Select Color in the main menu and press the [HOME] button. The COLOR menu appears, as shown in the following figure:

COLOR	
▶ WB Mode	Auto
RG Tuning	+6
BG Tuning	0
Saturation	100%
Hue	5
▲▼ Select Item	
◀▶ Change Value	
[Menu] Back	

➤ WB-Mode: White balance mode

Options:

- Auto
- Indoor
- Outdoor
- OnePush
- Manual

➤ RG: Red gain

Note: This feature is only effective when WB-Mode is set to Manual.

Options: 0~255

➤ BG: Blue gain

Note: This feature is only effective when WB-Mode is set to Manual.

Options: 0~255

➤ RG Tuning: Red gain fine-tuning

Note: This feature is only effective when AWB sens is set at Low.

Options: -10 ~ +10

➤ BG Tuning: Blue gain fine-tuning

Note: This feature is only effective when AWB sens is set at Low.

Options: -10 ~ +10

➤ Sat.: Saturation

Options: 60% ~ 200%

➤ Hue: Chroma adjustment Options: 0 ~ 14

4. IMAGE

Select Image in the main menu and press the [HOME] button. The IMAGE menu appears, as shown in the following figure:

IMAGE	
▶ Luminance	7
Contrast	9
Sharpness	3
Flip-H	Off
Flip-V	Off
B&W-Mode	Off
Gamma	0.45
Style	CStyle
▲▼ Select Item	
◀▶ Change Value	
[Menu] Back	

- Luminance: Brightness adjustment
Optional items: 0 ~ 14
- Contrast: Contrast adjustment
Options: 0 ~ 14
- Sharpness: Sharpness adjustment
Options:
 - Auto
 - 0 ~ 15
- Flip-H: Image flipped horizontal
Options:
 - On
 - Off
- Flip-V: Image flipped vertical
Options:
 - On
 - Off
- B&W-Mode: Image color
Options:
 - On
 - Off
- Gamma
Options:
 - Default
 - 0.45
 - 0.5
 - 0.56
 - 0.63
- Style
Options:
 - Norm
 - Clarity
 - Bright
 - CStyle

5. P/T/Z

P/T/Z	
▶ SpeedByZoom	On
AF Zone	Center
AF-Sense	High
L/R Set	STD
Display Info	On
Image Freeze	Off
Digital Zoom	Off
Call Preset Speed	24
▲▼ Select Item	
◀▶ Change Value	
[Menu] Back	

- SpeedByZoom: The depth of field scale switch
Options:
 - On
 - Off
- AF-Zone: Interested in focusing area
Options:
 - Top
 - Center
 - Bottom
- AF-Sense: Automatic focusing sensitivity options
Options:
 - Low
 - Normal

- High
- L/R Set
 - Optional items:
 - STD
 - REV
- Display Info
 - Options:
 - On
 - Off
- Image Freeze
 - Options:
 - On
 - Off
- Digital Zoom
 - Options:
 - 2X
 - 4x
 - 8X
 - 16X
 - Off
- Call Preset Speed
 - Options:
 - 1 - 24

6. NOISE REDUCTION

Select Noise Reduction in the main menu and press the [HOME] button.

The NOISE REDUCTION menu appears, as shown in the following figure:

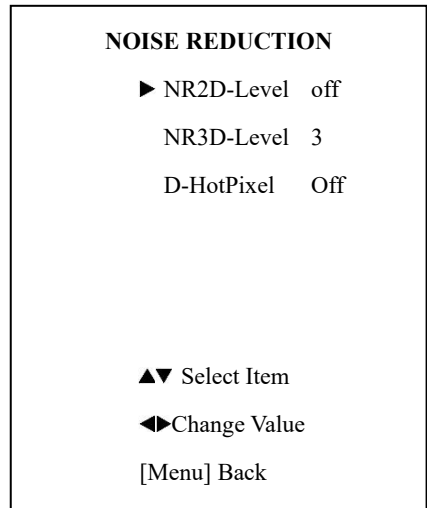

- NR2D-Level: 2D noise reduction
 - Options:
 - Off
 - Auto
 - 1 - 5
- NR3D-Level: 3D noise reduction
 - Options:
 - Off
 - 1 - 8
- D-HotPixel: Dynamic bad points
 - Options:
 - Off
 - 1 - 5

7. SETUP

Select Setup in the main menu and press the [HOME] button. The SETUP menu appears, as shown in the

following figure:

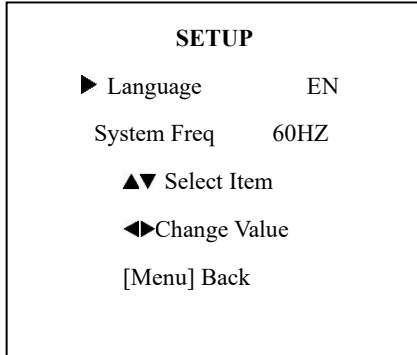

➤ Language: menu language

Options:

- EN
- Chinese
- Russian

➤ System Frequency

Options:

- 50Hz
- 60Hz

8. COMMUNICATION SETUP

Select Setup in the main menu and press [HOME] button. The COMMUNICATION SETUP menu appears, as shown in the following figure.

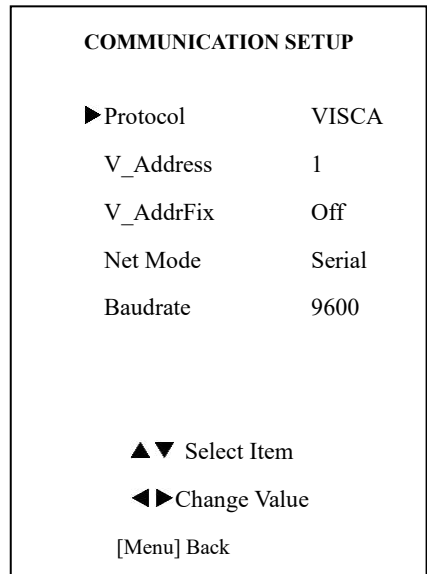

➤ Protocol: Control protocol type

Options:

- AUTO
- VISCA
- PELCO-D
- PELCO-P

➤ V_Address: Protocol address decided according to agreement (AUTO, VISCA protocol)

Options: 1 ~ 7

➤ P_D_Address: PELCO-D protocol

Options: 0 ~ 254

➤ P_P_Address: PELCO-P protocol

Options: 0 ~ 31

➤ V_AddrFix: Set whether users can change VISCA address through serial port or keyboard

Options:

- On (set to On, useless in 88 30 01 FF Command)
- Off

➤ Net Mode: Set the serial port control networking

Options:

- Serial
- Parallel

➤ Baudrate: Serial port baud rate

Options:

- 2400
- 4800
- 9600

- No

Note: Press [HOME] button to confirm.

9. RESTORE DEFAULT

Select Restore Default in the main menu and press the [HOME] button.

The RESTORE DEFAULT menu appears, as shown in the following figure:

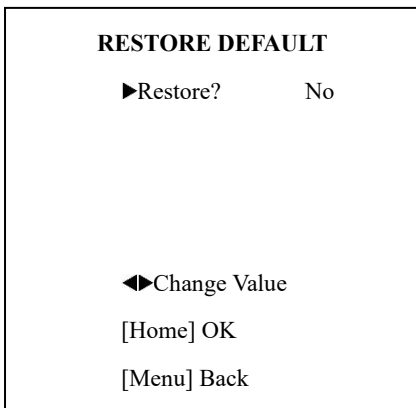

➤ Restore: Confirm restore factory settings

Options:

- Yes

USB 3.0

Camera supports UVC protocol, compatible USB 2.0 & USB 3.0.

USB 3.0 support 1920x1080p/30 max output.

Support OS: Windows 7/8/8.1/10, Linux, Mac OS, etc.

General software are as follows:

Windows: AMCAP, VLC, Debut Video Capture, etc.

Linux:V412 software driver and VLC media player, etc.

Mac OS: FaceTime. iChat, Photo Booth and Debut Video Capture, etc.

Note the following:

- ClearOne recommends the use of AMCAP version 8.0 in Windows, as its software performance is more stable. When you use the high version of AMCAP in a low configuration system, it shows the stream rendering.
- The first time the camera is accessed by USB cable, you must **install a plug-in**.

MAINTENANCE AND TROUBLESHOOTING

Camera Maintenance

- If you choose not to use your camera for a long time, turn off the power switch and disconnect AC power cord of AC adapter to the outlet.
- Use soft cloth to clean the camera cover.
- Use the soft dry cloth to clean the lens. If the camera is very dirty, clean it with diluted neutral detergent. Do not use any type of solvents, which may damage the surface.

Unqualified Application

- Do not shoot extremely bright objects for a long period of time, such as sunlight, strong light sources, etc.
- Do not operate in unstable lighting conditions, as image may flicker.

Troubleshooting

Problem	Solution
No image	<ol style="list-style-type: none">1. Check whether the power cord is connected, voltage is OK, POWER lamp is lit.2. Check whether the camera can self-test after start up.3. Check the video cable to make sure it is connected correctly.
Abnormal display of image	Check the video cable to make sure it is connected correctly.
Image dithering even at widest zoom position	<ol style="list-style-type: none">1. Check whether the camera is fixed correctly.2. Make sure there is nothing nearby causing vibrations.
The IR remote control cannot control the camera	<ol style="list-style-type: none">1. Change the remote control battery.2. Check the camera working mode.3. Check that the IR address of the Remote Commander is set correctly.
Serial communication cannot control the camera	<ol style="list-style-type: none">1. Check the camera working mode.2. Check that the control cable is connected correctly.