

## APPLICATION NOTE

### PRODUCTS SUPPORTED:

CONVERGE® Pro models: 880, 880T, 880TA, 840T, 8i, TH20, VH20, SR1212, SR1212A, INTERACT® Pro, INTERACT Pro 8i and StreamNet™ SLX300/SLX300i

CLEARONE DOCUMENT NTS-0022-001  
(REVISION 1.0) March, 2013

USING THE STREAMNET SLX300/SLX300i AS SOURCE TO A  
CONVERGE PRO OR INTERACT PRO AUDIO SYSTEM

### OVERVIEW

This document explains how to connect and use a StreamNet-connected SpeakerLinX SLX300/SLX300i as an audio source to a CONVERGE Pro or INTERACT Pro audio system. This will take any audio accessible to the SLX300/SLX300i through the StreamNet network, and feed it into the CONVERGE Pro or INTERACT Pro audio system.

CONVERGE Pro Systems		INTERACT Pro Systems
880	TH20	INTERACT Pro
880T	VH20	INTERACT Pro 8i
880TA	SR1212	
840T	SR1212A	
8i		

### APPLICATIONS

This document explains the wiring required to connect the SLX300 to a CONVERGE Pro or INTERACT Pro system.

**NOTE:** All references to the SLX300 are also applicable to the SLX300i.

#### Cable

The SLX300 left and right channel outputs are analog-balanced, using 3-pin mini phoenix-type connectors. You must construct one cable for each channel.

<b>SLX300 Balanced Audio Outputs</b>	<b>CONVERGE Pro or INTERACT Pro Mixer Inputs</b>
Pin 1 - Ground	Pin 1 - Positive
Pin 2 - Positive	Pin 2 - Negative
Pin 3 - Negative	Pin 3 - Ground

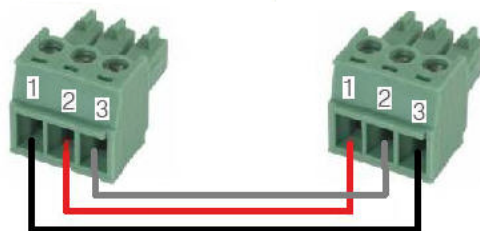

Make 2 Cables

## Wiring

Use the diagram below to connect your SLX300 outputs to the CONVERGE Pro or INTERACT Pro mixer inputs:

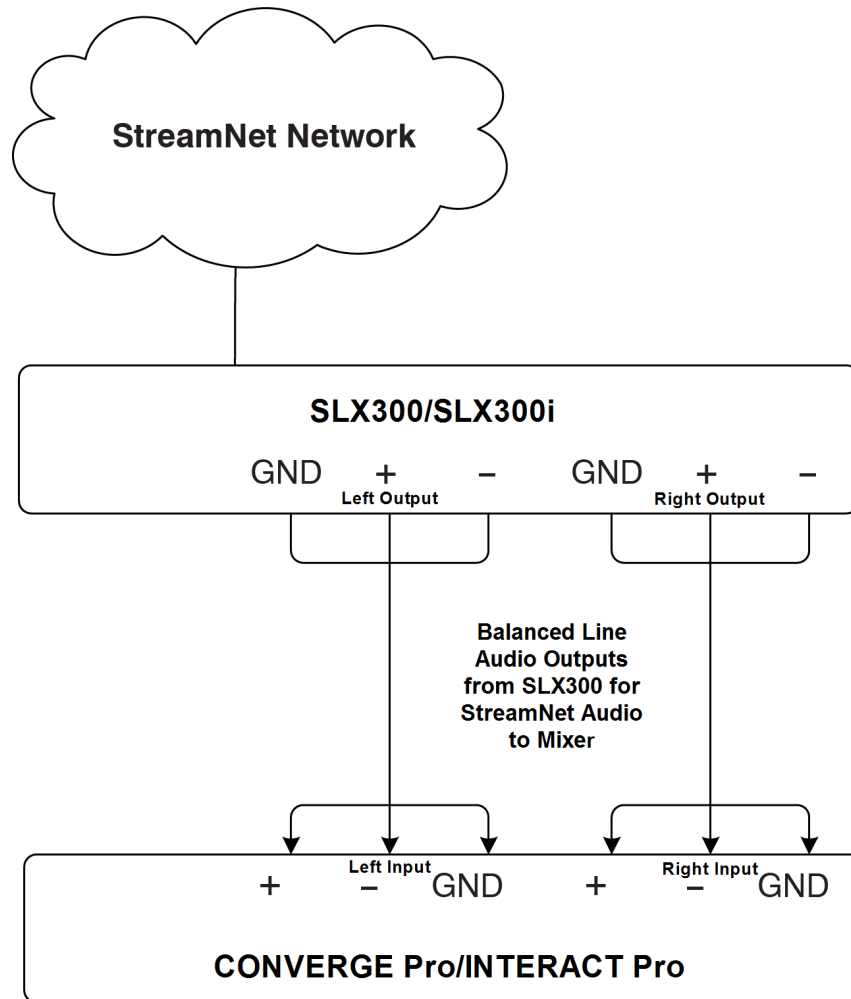

**NOTE:** To avoid audio instability, speakers should not be connected to the SLX300. The only speakers used should be connected to outputs on the CONVERGE/INTERACT Pro.

## Audio Control

The audio volume is adjusted by changing the gain level on the output of the CONVERGE Pro or INTERACT Pro. For more information on adjusting the gain level of the CONVERGE Pro or INTERACT Pro refer to the product manual available from the ClearOne web site: [www.clearone.com](http://www.clearone.com).

If there are questions about operation or setup of the CONVERGE Pro, INTERACT Pro or SLX300, please contact ClearOne Technical Support at 1-800-283-5936 or e-mail at [tech.support@clearone.com](mailto:tech.support@clearone.com).

### HEADQUARTERS:

**Salt Lake City, UT USA**  
5225 Wiley Post Way  
Suite 500  
Salt Lake City, UT 84116  
**Tel:** 801.975.7200  
**Toll Free:** 800.945.7730  
**Fax:** 801.977.0087  
**E-mail:** [sales@clearone.com](mailto:sales@clearone.com)

**EMEA**  
**Tel:** 44 (0) 1189.036.053  
**E-mail:** [global@clearone.com](mailto:global@clearone.com)

**APAC**  
**Tel:** +011.852.3590.4526  
**E-mail:** [global@clearone.com](mailto:global@clearone.com)

**LATAM**  
**Tel:** 801.974.3621  
**E-mail:** [global@clearone.com](mailto:global@clearone.com)

**TechSales**  
**Tel:** 800.705.2103  
**E-mail:** [techsales@clearone.com](mailto:techsales@clearone.com)

**Technical Support**  
**Tel:** 800.283.5936  
**E-mail:** [tech.support@clearone.com](mailto:tech.support@clearone.com)