

ClearOne®

VIEW® Pro

High-definition, IP, Compressed Audio/Video Encoder, and Decoder

Quick-Start Guide



Table of Contents

THE VIEW PRO ENCODER AND DECODER	1
QUICK-START OVERVIEW	1
MOUNTING THE ENCODER AND DECODER	2
THE ENCODER/DECODER IN NETWORK	7
CONNECTING THE ENCODER.....	7
CONNECTING THE DECODER.....	8
CONFIGURING THE ENCODER/DECODER.....	9
VIEW PRO ACCESSORY KITS.....	10
PART NUMBERS.....	12
CLEARONE CONTACTS.....	12

THE VIEW PRO ENCODER AND DECODER

The VIEW Pro E120 encoder takes digital video and audio from source devices, such as receivers, cable boxes or DVRs, and makes the source available anywhere on the StreamNet IP network. The VIEW Pro D110 decoder takes the combined video and audio stream, decodes it, and then sends the video and audio to a display such as a HDTV or projector and sound system.

IMPORTANT: The VIEW Pro E120 encoder and D110 decoder can only be used with a StreamNet network configured using StreamNet Dealer Setup software.

The latest version of the StreamNet Dealer Setup software can be found on the ClearOne website at:

http://www.clearone.com/resources#enterprise_streaming

QUICK-START OVERVIEW

These steps must be done in the following order to use the VIEW Pro encoders and decoders in your StreamNet network:

1. Mounting the Encoder/Decoder.
2. The Encoder/Decoder in Network
3. Connecting the Encoder/Decoder
4. Configuring the Encoder/Decoder.

VIEW PRO ENCODER/DECODER

MOUNTING THE ENCODER AND DECODER

The **VIEW Pro Encoder** includes **rack-mount ears** that attach to the encoder to facilitate mounting in a standard rack

The **VIEW Pro Decoder** includes **surface-mount ears** that attach to the decoder to facilitate mounting on top of a surface, under a surface, or on a wall. It **also includes mounting clips for the power supply**.

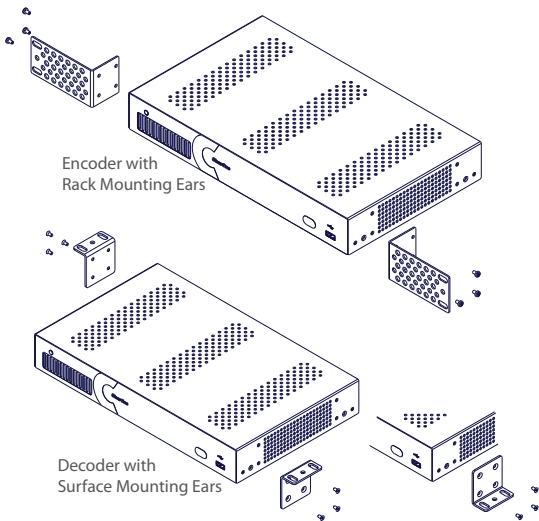

QUICK-START GUIDE

The power supply for the decoder can also be mounted to a wall using the included mounting clips.

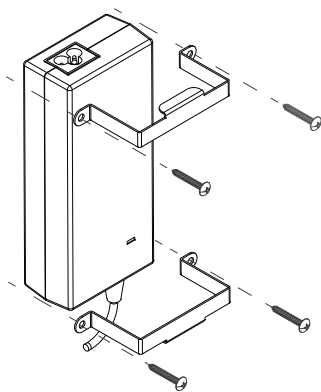

An optional VESA Mount Bracket Kit (910-0002-006) is available for applications where an encoder/decoder must be located on a VESA mount. The VESA Mount Bracket Kit (910-0002-006) includes a Wall Bracket that the can VESA Bracket can attach to.

NOTE: The VESA adapter does not attach the decoder to the back of a monitor, but allows the decoder to be attached to a separate VESA mount.

VIEW PRO ENCODER/DECODER

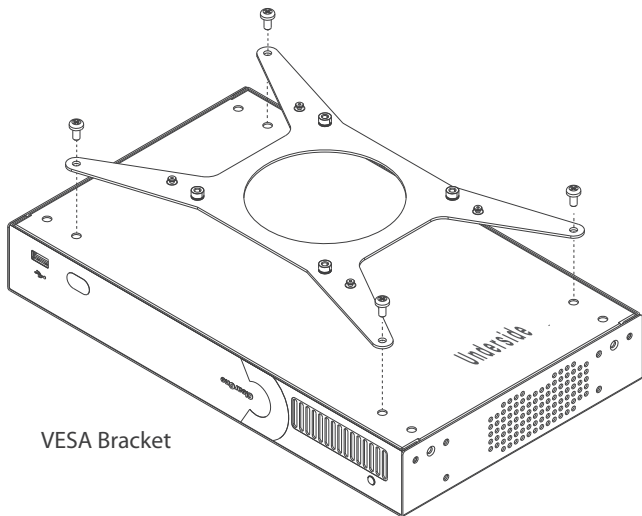

VESA Bracket

QUICK-START GUIDE

Wall Bracket
(Mount to stud or
other solid surface)

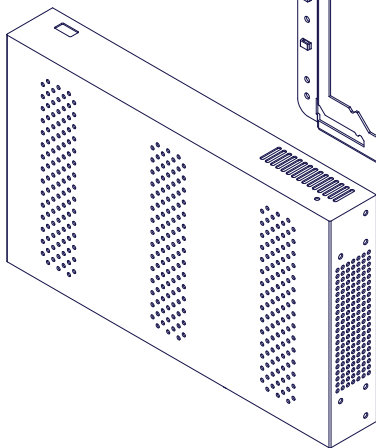
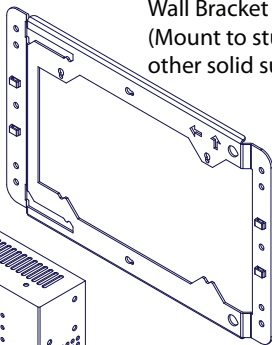

Unit with VESA Bracket
hangs on Wall Bracket

VIEW PRO ENCODER/DECODER

When the VIEW Pro cables cannot be concealed, cables can be surface mounted using the optional 910-0002-003 VIEW Pro Cable Raceway Kit. This raceway, in 12-inch joinable lengths, can be mounted to the wall to secure and cover the cables to the VIEW Pro devices.

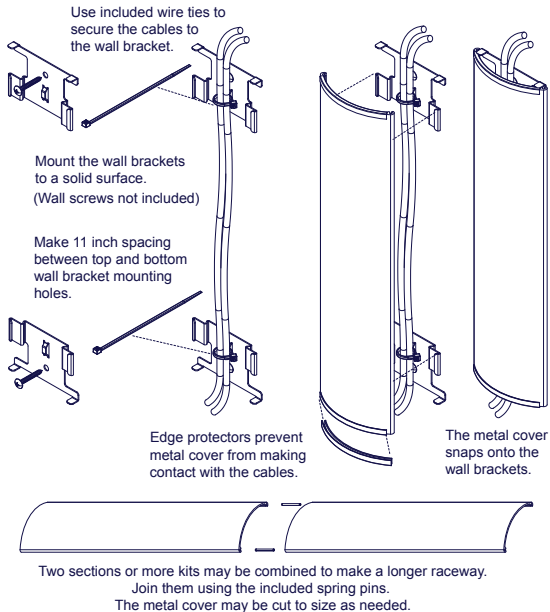

THE ENCODER/DECODER IN NETWORK

The VIEW Pro encoder receives input from an AV source device such as BluRay Player, DVD Player, etc. and distributes it over a StreamNet TCP/IP network using a standard 100 Mbit or Gbit Ethernet connection. The decoders, as counterparts, are installed at the locations of the target video displays. They operate together: the encoders providing the IP data for the decoders to deliver to the displays.

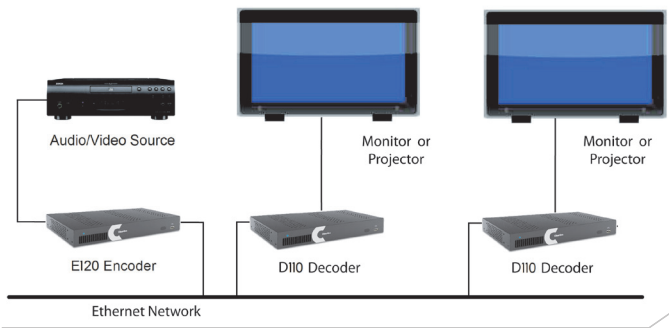

CONNECTING THE ENCODER

The VIEW Pro E120 Encoder connections are from the back of the unit as shown in the following diagram:

VIEW PRO ENCODER/DECODER

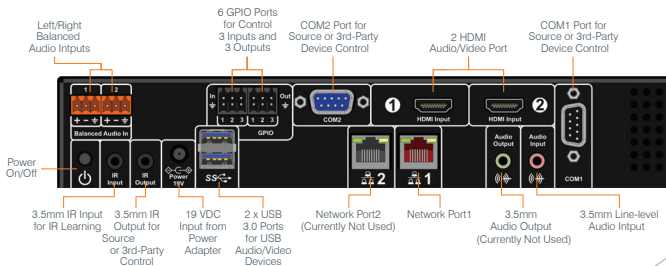

CONNECTING THE DECODER

The VIEW Pro D110 Decoder connections are from the back of the unit as shown in the following diagram:

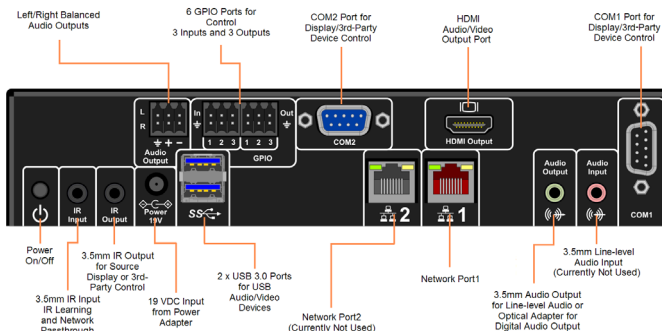

CONFIGURING THE ENCODER/DECODER

The VIEW Pro Encoder/Decoder is configured for use in the commercial or residential network using the StreamNet Dealer Setup program. StreamNet Dealer Setup is a PC-based program that allows you to configure devices so that they can communicate across a StreamNet network. Phases of the software setup include:

- Opening the existing project
- Add the new device
- Configuring the device with system-specific information regarding Display Outputs, Controls, IP and GPIO
- Saving the project
- Sending the configuration files to the server

These steps involved in these processes are detailed in the DigiLinX Dealer Setup manual available for viewing or download at www.ClearOne.com.

Information specific to the VIEW Pro Encoder is contained in the VIEW Pro - E120 Digital AV Encoder Installation and Users Manual available for viewing or download at www.ClearOne.com.

Information specific to the VIEW Pro Decoder is contained in the VIEW Pro - D110 Digital AV Decoder Installation and Users Manual available for viewing or download at www.ClearOne.com.

VIEW PRO ENCODER/DECODER

VIEW PRO ACCESSORY KITS

The following accessory kits are available to meet the mounting and control needs of your VIEW Pro Encoders and Decoders:

Part Number	Kit Name	Description
910-0002-001	VIEW Pro Rack Mount (Included with Encoder)	Rack Mount Kit for VIEW Pro Encoder E120, Decoder D110 <ul style="list-style-type: none">• 2X - Rack Ear, Extended length• 6X - Screw, M3 x 6mm, Pan-head, Phillips, Thread Locking, Black
910-0002-002	VIEW Pro Wall Mount (Included with Decoder)	Wall Mount Kit for VIEW Pro Encoder E120, Decoder D110 <ul style="list-style-type: none">• Bracket 1Ru Rack/Wall Mount• 2X - Screw, M3 x 6mm, Pan-head, Phillips, Thread Locking, Black• 2X - Bracket, 19V PSU Wall mount
910-0002-003	VIEW Pro Cable Raceway (Optional)	Cable Raceway Kit (12 inch) for Wall Mount Kit for VIEW Pro Decoder D110 <ul style="list-style-type: none">• 1X - Extrusion, Cable Raceway Cover, 12 inch• 2X - Bracket, Cable Raceway Wall-mount Clip• 2X - Cable Tie (4 inch)• 2X - Spring Pin, 5-64 inch x 1 inch• 2X - Plastic, Edge Protector, 3 inch

QUICK-START GUIDE

Part Number	Kit Name	Description
910-0002-004	VIEW Pro IR Receiver (Optional)	IR Receiver cable for VIEW Pro Encoder E120, Decoder D110 <ul style="list-style-type: none">• 1X - IR Receiver Assembly with 6 ft. cable
910-0002-005	VIEW Pro IR Receiver & Emitter (Optional)	IR Receiver Cable, IR Emitter Cable Kit for VIEW Pro Encoder E120, Decoder D110 <ul style="list-style-type: none">• 1X - IR Receiver with 6 ft. cable, 3.5 mm plug• 1X - IR Emitter with 6 ft. cable, 3.5 mm plug
910-0002-006	VIEW Pro VESA Bracket (Optional)	Wall Mount VESA Bracket Kit for VIEW Pro Encoder E120, Decoder D110 <ul style="list-style-type: none">• 1X - Bracket, VESA and Hanging Mount• 1X - Bracket, Wall Side Mount• 2X - Bracket, 19V PSU Wall mount• 4X - Screw, M4 X 6mm, Pan-Head, Phillips, Plain

VIEW PRO ENCODER/DECODER

PART NUMBERS

910-0000-001 VIEW Pro Encoder E120
910-0001-001 VIEW Pro Decoder D110

CLEARONE CONTACTS

HEADQUARTERS:

Salt Lake City, UT USA

5225 Wiley Post Way
Suite 500
Salt Lake City, UT 84116

Sales: 800.705.2103

Toll Free: 800.945.7730

Fax: 801.303.5711

e-mail: sales@clearone.com

EMEA:

Tel: +44 (0) 1189.036.053

e-mail: global@clearone.com

LATAM:

Tel: 801.974.3621

e-mail: global@clearone.com

TechSales

Tel: 800.705.2103

e-mail: techsales@clearone.com

Technical Support

Tel: 800.283.5936

e-mail: tech.support@clearone.com

APAC:

Tel: +852.3590.4526

e-mail: global@clearone.com

Middle East:

Tel: +852.3590.4526

e-mail: global@clearone.com

© 2014 ClearOne, Inc. All rights reserved.

Information in this document is subject to change without notice. QSG-0010-001 Revision 1.1 October, 2014